

UNITED STATES PATENT OFFICE.

MARTIN LANDENBERGER, OF PHILADELPHIA, PENNSYLVANIA.

BOTTLE-STOPPER.

SPECIFICATION forming part of Letters Patent No. 665,689, dated January 8, 1901.

Application filed June 21, 1900. Serial No. 21,042. (No model.)

To all whom it may concern:

Be it known that I, MARTIN LANDENBERGER, a citizen of the United States, residing at Philadelphia, in the county of Philadelphia and State of Pennsylvania, have invented certain new and useful Improvements in Bottle-Stoppers, of which the following is a specification.

My invention relates to a bottle-stopper, and has for its object to provide a stopper which by the coaction of a bail the stopper is conveniently and securely forced to seat within the neck of the bottle to effectually seal the contents of the bottle from atmospheric influence, this result being attained by simply turning the bail to cause the same to ride upon cam-faces formed in the stopper. The main object, however, is to provide an inexpensive bottle-stopper that shall be adaptable to bottles of any form, that shall be convenient to operate, and that shall hermetically seal the bottle when the bail is given a partial revolution, this revolution being commensurate with the degree of pressure desired upon the stopper to seal the bottle.

In the drawings, Figure 1 is an elevation of a sufficient portion of the neck of the bottle to illustrate the operation of the stopper, the stopper being shown firmly seated within the neck by reason of the bail having been turned to cause the horizontal portion of the bail to ride upon the cam-faces of the stopper, and thereby force the same into the neck of the bottle a sufficient distance to hermetically seal the bottle. Fig. 2 is a view showing the bail within the vertical slot with the stopper in position to be forced to its seat when the bail engages with the cam-faces of the stopper and is turned to ride upon the same. Fig. 3 is a like view in side elevation, showing in full and dotted lines the position of the horizontal portion of the bail when the stopper is firmly seated by reason of the bail having been urged to ride upon the cam-faces of the stopper. Fig. 4 is a horizontal section of the stopper, taken on lines *xx*, Fig. 2, a portion of the top of the stopper being removed.

The invention consists in the parts and combination of parts hereinafter described and claimed.

1 designates the neck of the bottle, to which is attached a bail 2 by any preferred

means, so that the bail may be given a partial turn upon the neck of the bottle, as shown. The bail is secured by means of a wire 3, coiled at diametrically opposite sides, as at 4, and secured at the free ends by twisting, as at 5. The bail 2 is formed with a central horizontal portion 6, depending arms 7, and inwardly-bent portions 9, which enter the coils 4, as at 8, and swing therefrom.

The stopper 10 is formed with a lower portion 11 to enter the neck of the bottle, and a head portion 12, formed with a vertical slot from which at the extreme upper end diverges in opposite radial directions cam-faced slots 14, adapted to receive the bail when the stopper is partially seated, when by a partial revolution of the bail the horizontal portion 7 will engage with the cam-faces 15 at their lowest points, and by a further turn of the bail the portion 7 thereof will continue to ride upon the cam-faces and force the stopper to its seat.

The operation just described is conveniently performed by grasping the body of the bottle in one hand, when by giving a slight pressure to the cork with the opposite hand, and giving the bail a partial turn the stopper is either forced to its seat or released therefrom.

It will be seen that the stopper is inexpensive of construction, as it may be made of porcelain, galvanized metal, or any non-corrosive material, with a cork or rubber portion to enter the bottle, if desired, and that any form of bail or fastening for the bail may be employed, so that there is a horizontal portion to ride upon the cam-faces, and thereby force the stopper into the neck of the bottle.

If desired, I may form one or more coils 16, Fig. 3, in the bail 2, against which the finger or thumb may press in giving the bail a partial revolution.

What I claim is—

As a new article of manufacture a stopper formed with a lower portion to enter the neck of the bottle and seal the same, and a head portion formed with a vertical transverse slot extending entirely through the same from a point slightly below the upper end of the head portion to a point slightly above the lower portion, the walls of the slot being cut away at the upper end thereof from a point at substan-

5 tially the transverse center thereof to the periphery of the stopper, at an angle from the walls of the transverse slot, said cut-away portion extending in opposite directions upon opposite sides of the transverse slot, the said stopper being formed of a solid body, and the said slot and cut-away portion thereof being formed in the solid material thereof,

a bail passing through the slot, and means for securing the bail upon the bottle. 10

In testimony whereof I affix my signature in presence of two witnesses.

MARTIN LANDENBERGER.

Witnesses:

WILLIAM WEBSTER,
W. R. EVANS.

No. 665,689.

Patented Jan. 8, 1901.

M. LANDENBERGER.
BOTTLE STOPPER.

(Application filed June 21, 1900.)

(No Model.)

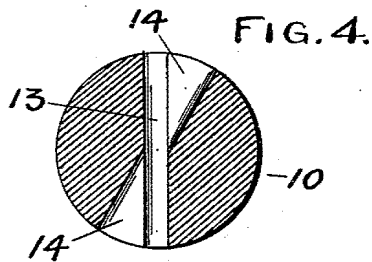
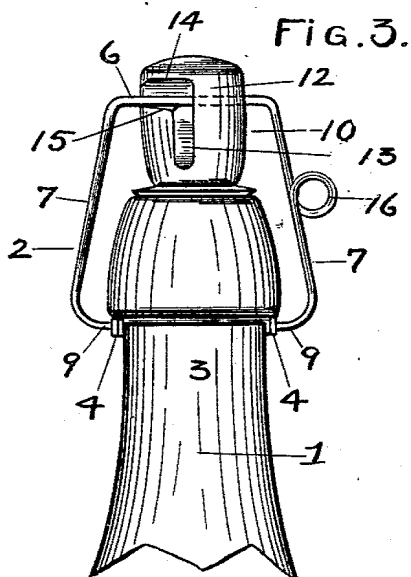
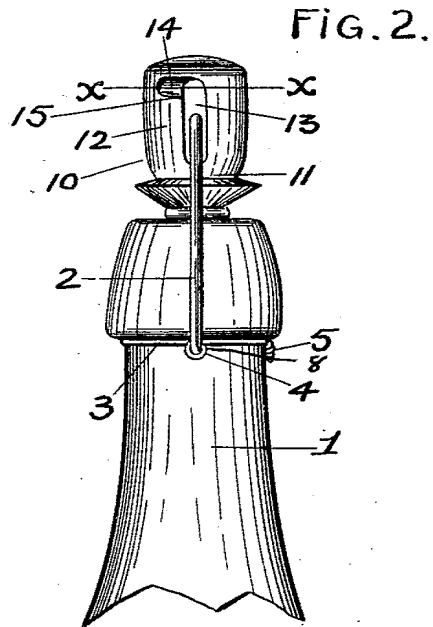
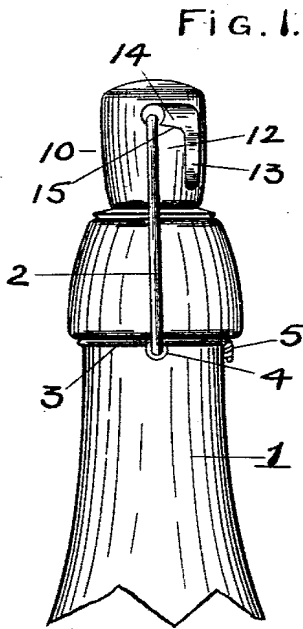

WITNESSES.
C. J. Webster.
Wm. Scott

INVENTOR.
MARTIN LANDENBERGER
By *William Webster*
ATTORNEY.